

FRONT AXLE MINIMUM LOAD GUIDELINES

The following document has been prepared by Transport Certification Services (TCS) to provide basic guidance to vehicle modifiers when modifying and/or loading a heavy vehicle, particularly when installing bodies or heavy equipment toward the rear of a vehicle.

TCS is the exclusive Asia-Pacific distributor of TrailerWIN software that can conduct weight distribution calculations.

These guidelines are supplied without prejudice and free of charge to assist modifiers. TCS will not be held liable for any problems that arise from sole reliance on, or misinterpretation of, these guidelines or from the introduction of new rules after the issue date of these guidelines. The following documents/items should be read in conjunction with these guidelines:

1. Vehicle Manufacturer (OEM) Modification Guidelines (*takes precedence over VSB-6 and TCS guidelines*)
2. Vehicle Standards Bulletin 6 (VSB 6 – takes precedence over TCS guidelines)
3. Load Restraint Guide 2018
4. Disclaimer on the last page of this document

All modifications must be carried out by suitably qualified tradespeople in accordance with the relevant Australian Design Rules, Australian Standards and National Codes of Practice. Any uncertainties should be discussed with TCS prior to commencing the modification. **These guidelines are not intended to be used as the sole instructional tool for vehicle modifiers; modifiers must be suitably qualified tradespeople who are experienced in modifying heavy vehicles. These guidelines do not necessarily provide all the necessary information to carry out a weight distribution assessment and must only be used as a supplementary quick reference guide.**

The steering, braking and suspension systems of a heavy vehicle are designed to operate safely and effectively over a wide range of loading and operating conditions. To ensure a heavy vehicle remains safe, it is essential to load the vehicle correctly.

These guidelines provide an insight into how incorrect load distribution between the axles can be problematic, and measures that should be taken to avoid adverse effects on safety, function, and handling.

FRONT AXLE MINIMUM LOAD GUIDELINES

Front (Steer) Axle Loading:

Heavy vehicles are designed by their manufacturer to safely carry a wide range of loads, varying from an unloaded tray or prime mover to a fully-laden rigid body. Due to this, the vehicle can respond very differently under different loading conditions.

When loading a vehicle, the chassis can often be simplified as a basic lever or see-saw pivot about the rear-axle group. For example, placing a load at the very rear of the vehicle behind the rear axle group will effectively 'lift up' the front to some degree. While this effect is not usually visible, the amount of weight being transferred through the wheels to the road will increase at the rear axle group and decrease at the front axle group. With a sufficiently heavy load placed at the rear, the front wheels may not have enough weight over them to safely steer or brake the vehicle or in extreme cases could lift up off the ground completely during transit, see Figure 1.

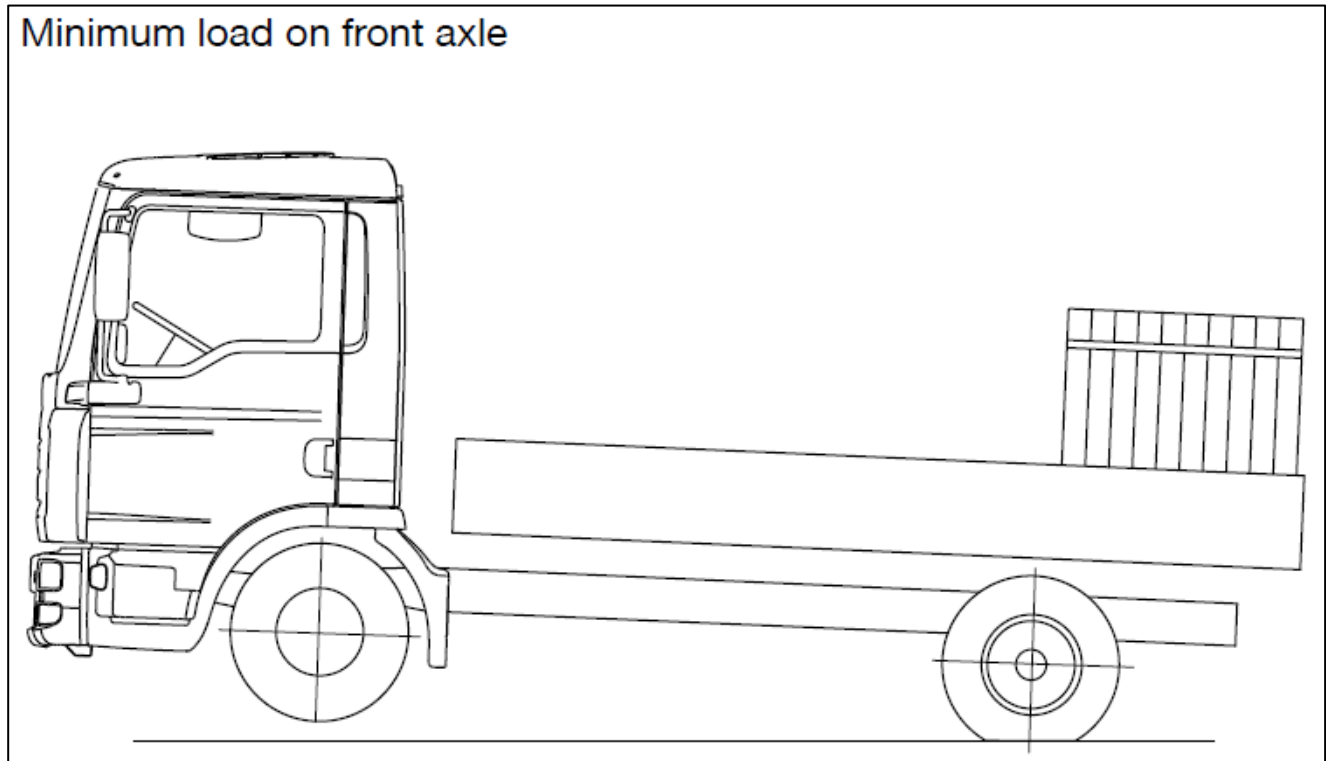

Figure 1: Sourced from MAN Guidelines 2014

FRONT AXLE MINIMUM LOAD GUIDELINES

The location of the effective centre of each axle group depends on the number of axles in the group. For a single axle the effective centre is located at the axle (see Figure 2 & front axle of the vehicle in Figure 3). For a twin/tandem axle group with load sharing suspension and identical weight ratings and tyre configurations on all axles in the group, the effective centre is located at the centrepoint between the two axles (see Figure 4 & rear axle group of the vehicle in Figure 3).

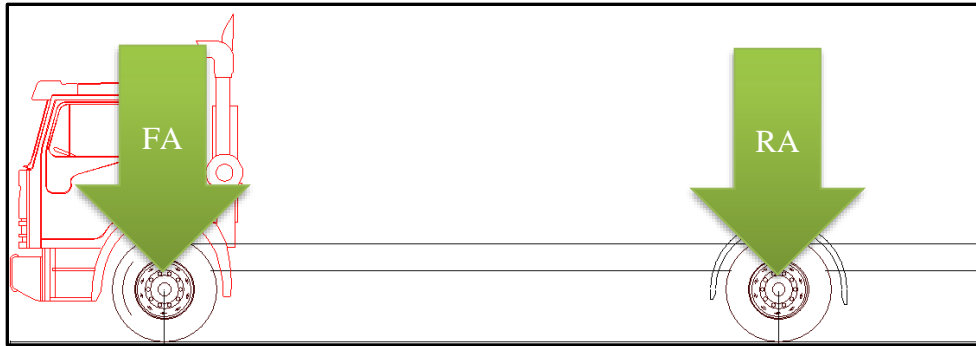

Figure 2: Effective axle centre 4x2

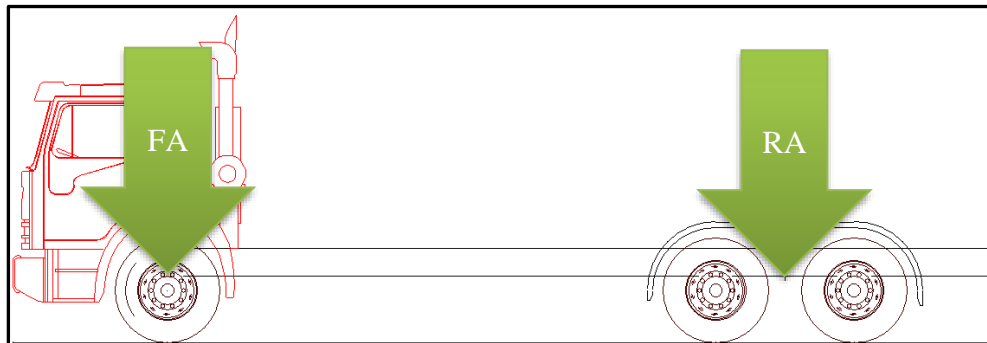

Figure 3: Effective axle centre 6x4

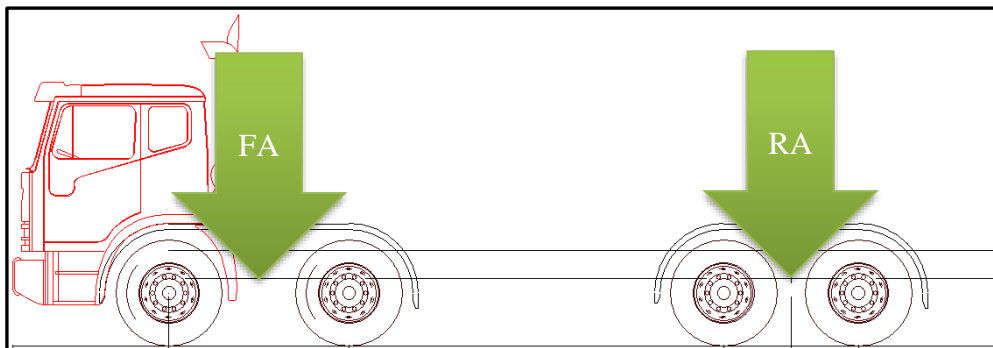

Figure 4: Effective axle centre 8x4 (Assuming Load Sharing suspension on Front Axle Group)

FRONT AXLE MINIMUM LOAD GUIDELINES

The front axle (or front axle group for an 8x4 'twin-steer' vehicle) contributes significantly in controlling the direction of the whole vehicle. The tyres grip the road to move the vehicle in any direction (accelerating, braking or steering), and the grip available depends on the road surface and the weight of the vehicle pushing the tyre into the road. Heavier loads require more grip to change direction, and so the amount of weight required for the steer tyres to grip effectively is also higher. Driving a vehicle with not enough of its weight distributed over the front axle/axles results in a very light steering feel, and makes it difficult to change direction or brake, especially in an emergency situation. These problems worsen when a truck is travelling uphill. If there isn't enough of the weight distributed over the rear, there is a higher chance of the rear brakes locking, or a trailer pushing the combination into a jackknife.

Placing a load exactly the same distance from the centre of each axle group will balance that load equally between the axle groups (Figure 5.2). Placing a load closer to the front than the rear of the vehicle distributes more of that load to the front axle(s) and less to the rear, while placing a load closer to the rear than the front of the vehicle distributes more weight to the rear and less to the front (Figure 5.3). When designing a vehicle modification it is critical to consider this load distribution, ensure that the unladen vehicle is safe, and ensure it is simple to correctly load the vehicle during service.

In OEM guidelines, weight over the front axle is generally expressed as a proportion of total vehicle weight. Different vehicle manufacturers require different proportions of the total vehicle weight to be over the front axle and may vary for different vehicle layouts and configurations, such as 4x2, 6x4, 8x4 in stand-alone configurations or in combination with a conventional trailer.

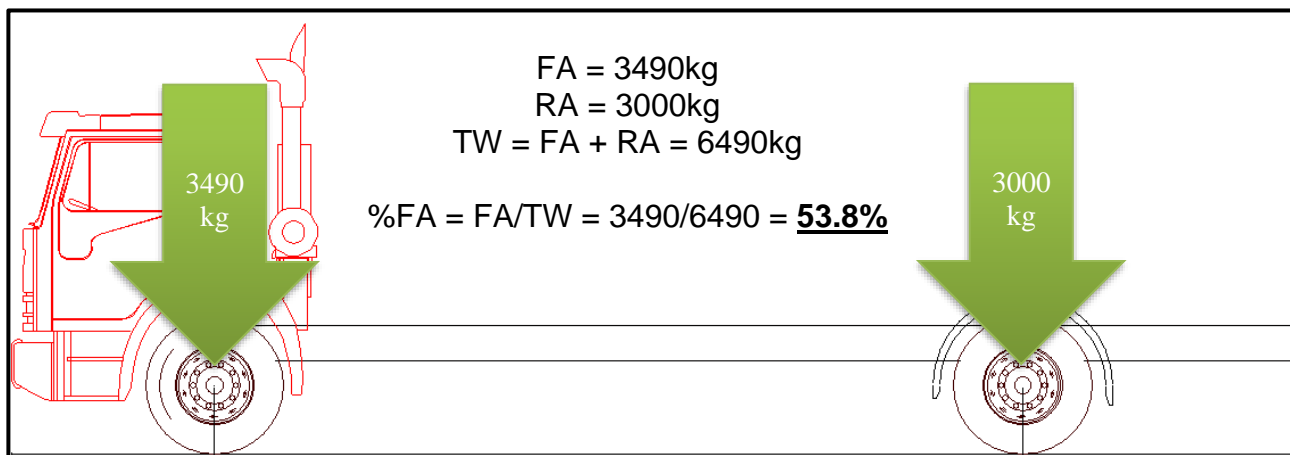

Figure 5.1: Example of unloaded weight distribution (Tare weight)

FRONT AXLE MINIMUM LOAD GUIDELINES

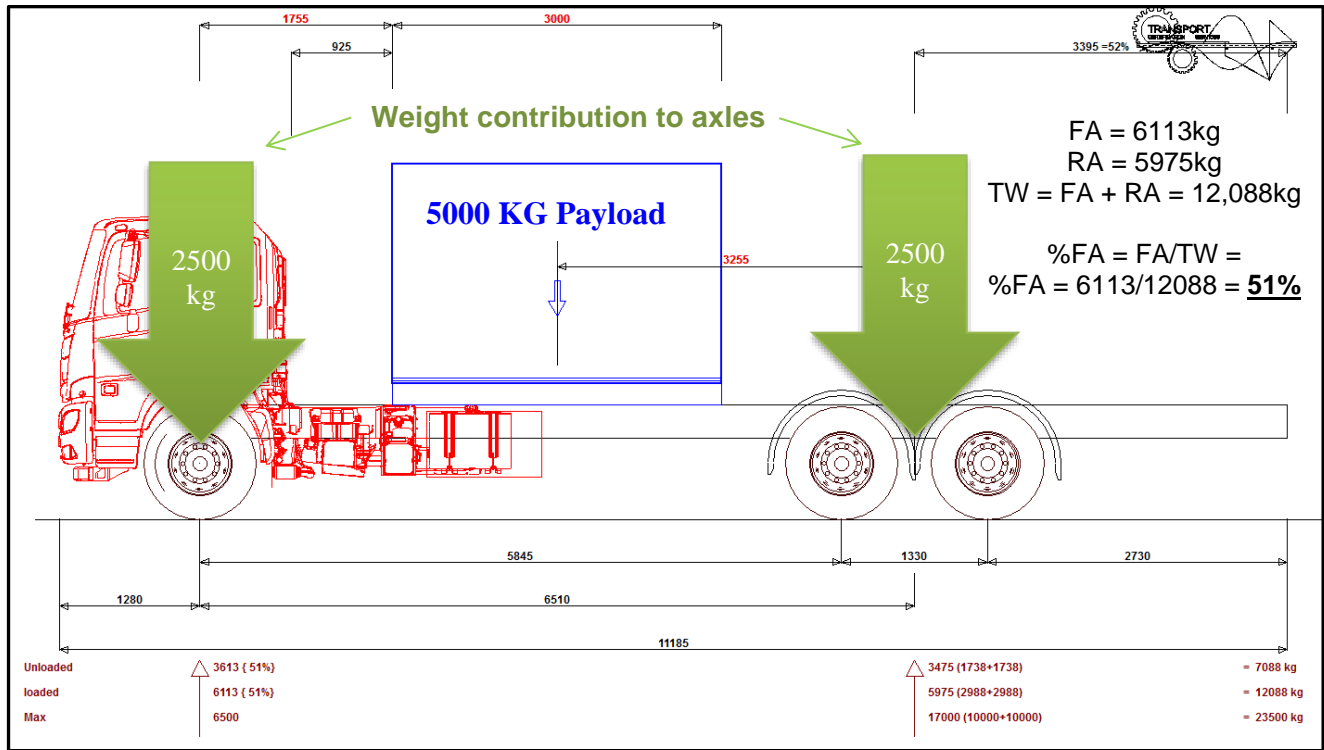

Figure 5.2: 5000kg centralised load and resultant weight over front and rear axle.

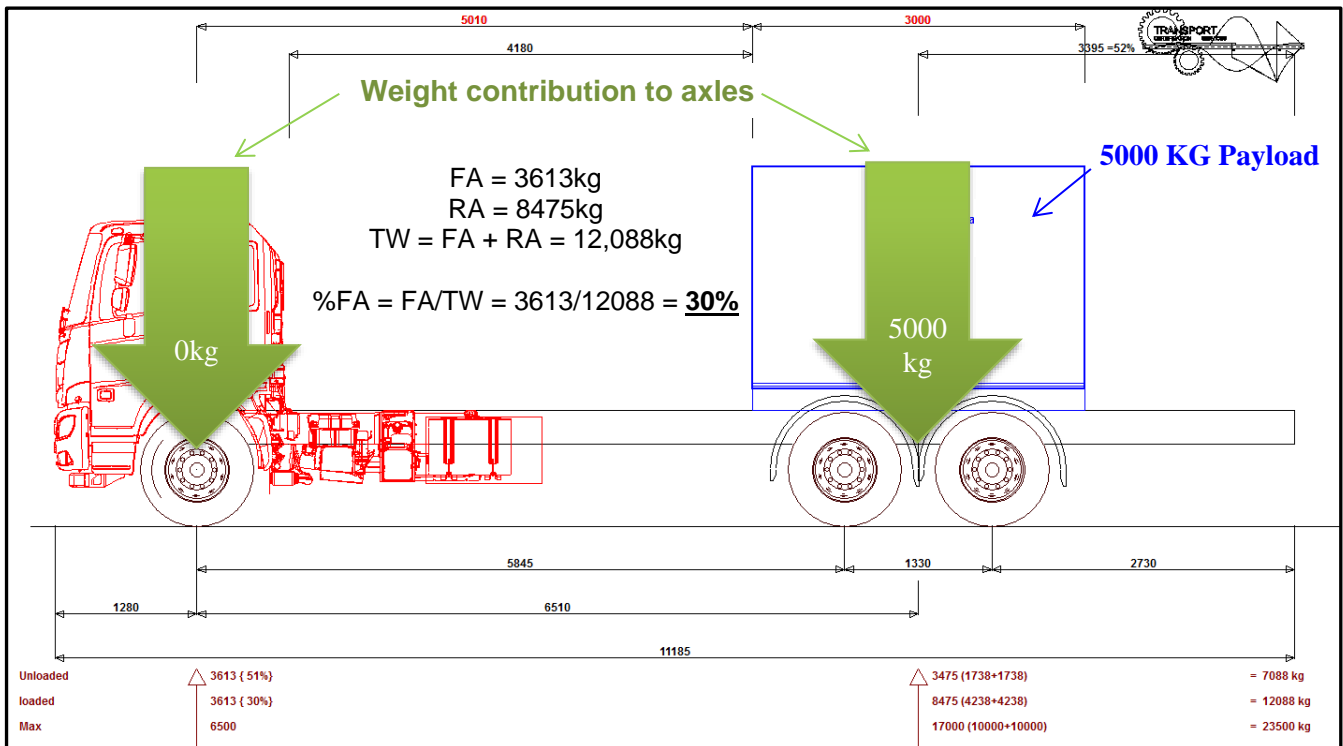

Figure 5.3: 5000kg load directly over the rear axle and resultant weight over front and rear axle

FRONT AXLE MINIMUM LOAD GUIDELINES

From the above calculations, it is clear that the position of the load has a substantial impact on the proportion of the total weight of the vehicle over the front axle; Please note that the values used are arbitrary and calculations are for illustrative purposes only.

It is important to note that different vehicle manufacturers require different proportions of the total vehicle weight to be over the front axle in all cases, and not just when the truck is carrying a load. The installation of bodies, goods loading devices and wheelbase modifications are typical examples of modifications that can influence the proportion of total weight of a vehicle over the front axle or axle group.

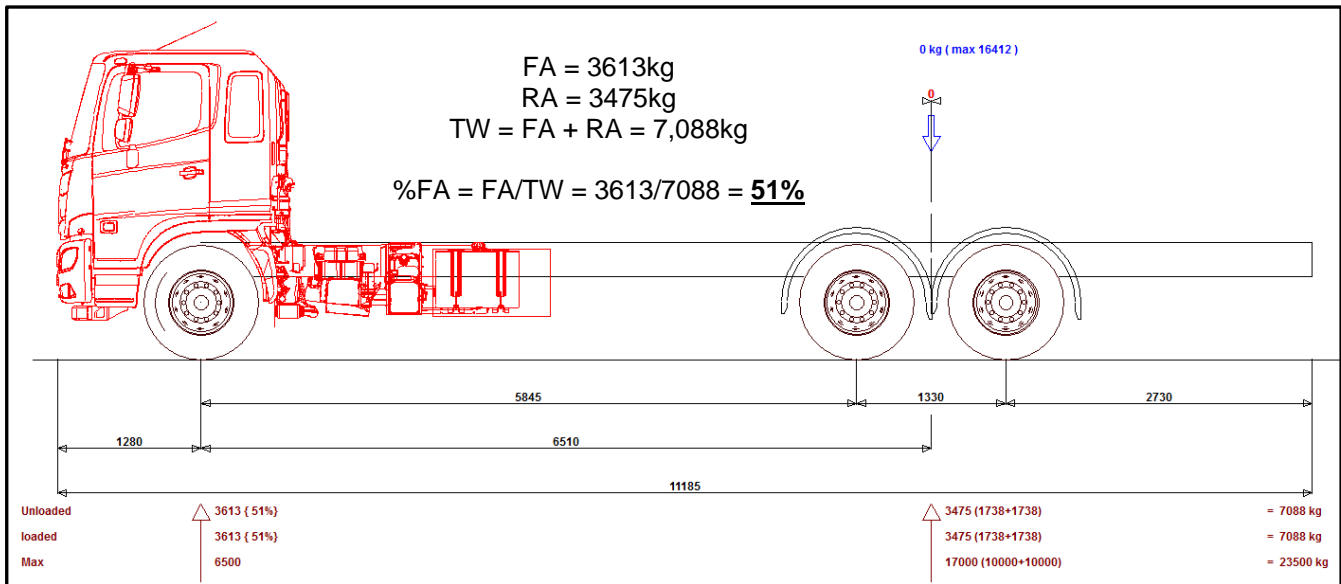

Figure 6.1: Hino FM 2628 – Extra Long Cab Chassis

FRONT AXLE MINIMUM LOAD GUIDELINES

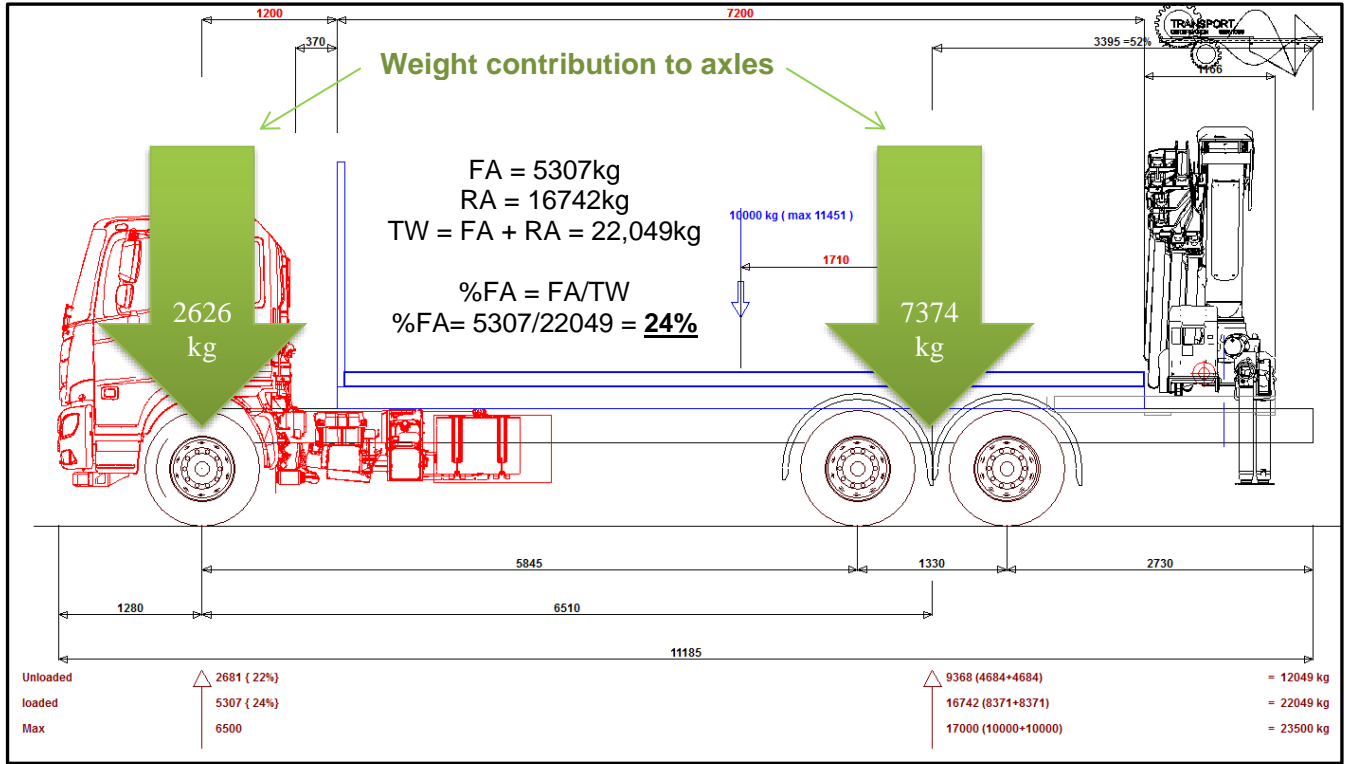

Figure 6.2: Hino FM 2628 – with 10,000kg central payload on tray and rear mounted crane

FRONT AXLE MINIMUM LOAD GUIDELINES

Manufacturer	Configuration	4x2, 4x4	6x2,6x4, 6x6	8x4	Reference	Models
HINO	Rigid	30%	20%	30%	HINO TRUCKS Body Mounting Manual (2012)	ALL
	Prime Mover	30%	20%	N/S		
FUSO	All configurations and load conditions	25%			Body/equipment mounting directive Australia/New Zealand (2013-2015)	ALL
DAF	In combination with mid-axle trailer	30%			Bodybuilder guidelines, DAF LF, CF and XF105 (2012)	LF, CF and XF105
	Solo or in combination with conventional coupled trailer	20%				
IVECO	Loads concentrated on the rear overhang.	25%			Stralis Euro 6 Bodybuilder Instructions (2013), Eurocargo MY2016 Bodybuilder Instructions (2017), Trakker Euro 4/5 Bodybuilder Instructions (2008)	Stralis, Eurocargo, Trakker
	Uniformly distributed loads	20%				
	All other configurations and load conditions	25%			Daily E6 Body Builders Instructions (2016)	Daily
N/S - Not shown in reference						

FRONT AXLE MINIMUM LOAD GUIDELINES

Manufacturer	Configuration	4x2, 4x4	6x2,6x4, 6x6	8x4	Reference	Models
KENWORTH	All configurations and load conditions	Weight under the front axle must always be higher than the weight under the front axle of the cab-chassis			Kenworth Trucks Body and Equipment Mounting Guide, January 2013	ALL
MACK	All configurations and load conditions	Contact Manufacturer				ALL
MAN	With rear VMLS	30%	25%*	Man Guidelines to fitting bodies Truck (2014)	TGM,TGL, TGS,TGX	
	In combination with trailer*** (GTM<=18t)	30%**	25%*			
	In combination with trailer*** (GTM>18t)	35%	30%*			
	In combination with trailer*** (GVM 7.5 - 15t)	30%	N/A			
	Other	25%	20%			
<p>* -2% for steered leading/trailing axles, only applies to vehicles that are loaded and unloaded with payloads ** Reduce to 25% if TGS/TGX Series or TGM Series with 18t GVM *** Refers to rigid-drawbar and centre-axle trailers only</p>						

FRONT AXLE MINIMUM LOAD GUIDELINES

Manufacturer	Configuration	4x2, 4x4	6x2,6x4, 6x6	8x4	Reference	Models
Mercedes-Benz	2 axles w/ rear goods loader or trailer (Truck:Trailer combination ratio < 1:1)	30%		N/S	Body/Equipment Mounting directives for Trucks, Atego BM 967x Book II - Technical Description (2017), Body/Equipment Mounting directives for Trucks, Actros/Antos BM 963x Book II - Technical Description (2018)	Atego, Actros, Antos, Arocs
	As above w/ Truck:Trailer combination ratio > 1:1	35%		N/S		
	2-axle, 3-axle & 4 axle (22% possible in solo operation with 'standard' centre of gravity)	25%				
	Solo 2 and 3 axle (Need to consider centre of gravity - 19% in the case of waste disposal vehicle upon request)	22%			Body/Equipment Mounting directive, Econic Euro VII, Model designation 956.xxx Book II - Technical Description (2014)	Econic
	2-axle w/ rear goods loader or trailer (Truck:Trailer combination ratio > 1:1)	35%		N/S		
	2-axle w/ readr goods loader or trailer (Truck:Trailer combination ratio < 1:1)	30%		N/S		
	Other	25%				
N/S - Not shown in reference						

FRONT AXLE MINIMUM LOAD GUIDELINES

Manufacturer	Configuration	4x2, 4x4	6x2,6x4, 6x6	8x4	Reference	Models
Scania	All configurations and load conditions	20%			Axle weight calculations', Scania Truck Bodybuilder (2017)	ALL
UD	All configurations and load conditions	Contact Manufacturer				ALL
VOLVO	All configurations and load conditions	20%		N/S	BODY BUILDER INSTRUCTIONS, Volvo Truck Corporation (2018)	FM, FH, FL, FE
Western Star	All configurations and load conditions	Contact Manufacturer				ALL
ISUZU	All configurations and load conditions	Contact Manufacturer				ALL
N/S - Not shown in reference						

FRONT AXLE MINIMUM LOAD GUIDELINES

ABOUT THESE GUIDELINES:

These guidelines are published by Transport Certification Services (TCS) to assist vehicle modifiers to conduct modifications in accordance with the OEM Requirements, Australian Design Rules, Vehicle Standards Bulletins and good engineering practice. These guidelines are not, nor are intended to be, complete or without exceptions. The guidelines are a guide only and their use is entirely voluntary. Recommendations may not be suitable for, or applicable to, all modifications. Modifiers should consider their own circumstances, practices and procedures when using these guidelines. Modifiers must comply with the Australian Design Rules (ADRs), the Australian Vehicle Standards Regulations, Vehicle Standards Bulletins (VSBs), the Roadworthiness Guidelines and any specific information and instructions provided by OEMs in relation to vehicle's systems and components. No endorsement of products or services is made or intended. Diagrams, where used in these Guidelines, are for illustrative purposes only.

Suggestions or comments about these guidelines are welcome. Please write to the Manager, Transport Certification Services, 14/69 Acacia Road, Ferntree Gully, VIC 3156.

DISCLAIMER:

Transport Certification Services makes no representations and provides no warranty that the information and recommendations contained in these guidelines are suitable for use by or applicable to all modifiers, up to date, complete or without exception. Reliance upon or use of the information or recommendations is voluntary and the user accepts all risks and responsibility for any such reliance or use and to the maximum extent permitted by law Transport Certification Services excludes all liability to any person arising directly or indirectly out of any such reliance or use.

TCS is committed to continual improvement and as such reserves the right to update or change these guidelines without notice.

© 2018 Transport Certification Services

This work is copyright. Apart from uses permitted under the Copyright Act 1968, no part may be reproduced by any process without prior written permission from Transport Certification Services. Requests and inquiries concerning reproduction rights should be addressed to the Manager, Transport Certification Services, 14/69 Acacia Road, Ferntree Gully, VIC 3156 or info@transportengineer.com